

- NOTES:
- DO NOT SCALE. USE FIGURED DIMENSIONS ONLY.
 - THIS DRAWING IS TO BE READ IN CONJUNCTION WITH ALL OTHER RELEVANT ARCHITECTURAL AND ENGINEERING DRAWINGS.

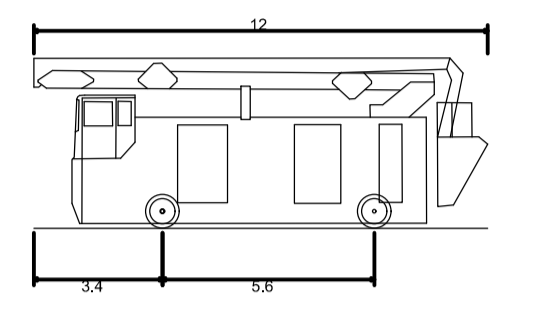

Aerial Platform/ Turntable Ladder/ Special Appliance
 Overall Length 12.000m
 Overall Width 2.550m
 Overall Body Height 4.500m
 Min Body Ground Clearance 0.130m
 Track Width 2.550m
 Lock-to-lock time 4.00s
 Curb to Curb Turning Radius 13.750m

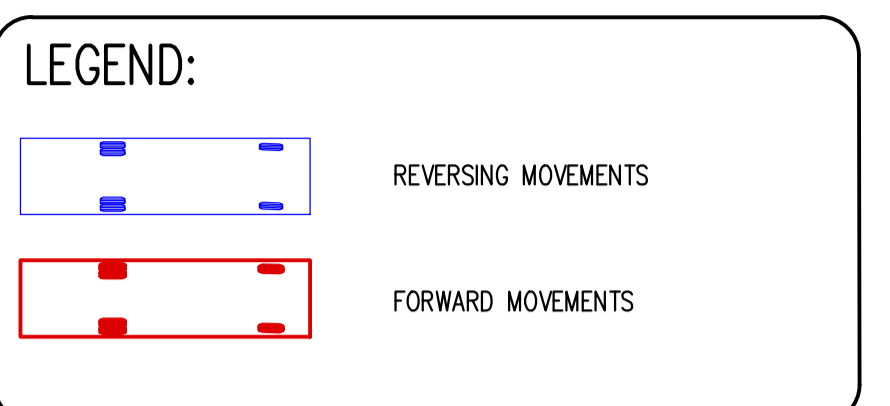
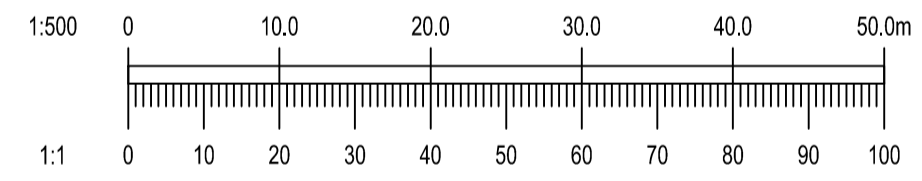

16/03/22	AN BORD PLEANALA SUBMISSION	PW	EC
REV. DATE	AMENDMENT	DRN	APPD

STATUS **FOR PLANNING ONLY
NOT FOR CONSTRUCTION**

Waterman Moylan
 Engineering Consultants

BLOCK S, EASTPOINT BUSINESS PARK, ALFIE BYRNE ROAD,
 DUBLIN D03 K7W7 IRELAND.
 Tel: (01) 664 8900 Fax: (01) 661 3618
 Email: info@waterman-moylan.ie www.waterman-moylan.ie

CLIENT CAIRN HOMES PROPERTIES LTD.
 ARCHITECT MCOORM ARCHITECTS

PROJECT SHD AT HOLYBANKS,
 SWORDS

TITLE SWEPT PATH ANALYSIS –
 HIGH REACH FIRE TENDER

DRAWN PW	DESIGNED LRG	APPROVED EC	DATE MARCH 2022
SCALE 1:500 @ A1	JOB NO. 17-088	DRG. NO. P015	REVISION -

© 2015. This drawing is copyright. No part of this document may be re-produced or transmitted in any form or stored in any retrieval system of any kind without the written permission of the consulting engineer or copyright holder except as agreed for use on the project for which the document was originally issued.